

# NITÖ T L

by Dominik Lutz , 2019

Suspension lamp. Structure fixed to the ceiling with stem, available in two heights. Extruded aluminium profile with free rotation system for direct and indirect light, graphite matt electroplated. Dimmable 1-10V driver and pcb led both included.

Type: Suspension lamp

Environment: Indoor

Structure: Aluminium

Voltage: 230 V

Supply: Terminal strip

Dimmable driver included



Light source: PCB LED 50W 3000K 4600Lm  
included

NITÖ T L

149000600010 graphite matt

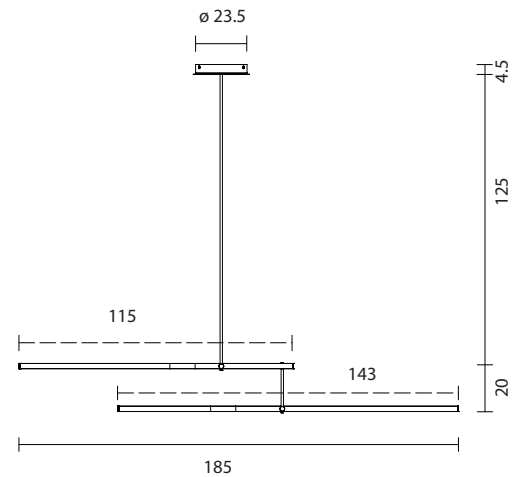
 2.8 kg  
5 kg



CE   IP-20

# NITŌ T S

by Dominik Lutz , 2019

Suspension lamp. Structure fixed to the ceiling with stem, available in two heights. Extruded aluminium profile with free rotation system for direct and indirect light, graphite matt electroplated. Dimmable 1-10V driver and pcb led both included.

Type: Suspension lamp

Environment: Indoor

Structure: Aluminium

Voltage: 230 V

Supply: Terminal strip

Dimmable driver included



Light source: PCB LED 50W 3000K 4600Lm  
included

NITŌ T S

148000600010 graphite matt

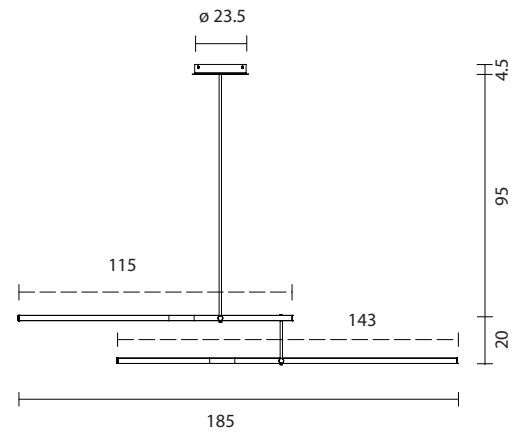
 2.8 kg  
5 kg



CE   IP-20

**NITÖ T L**  
by Dominik Lutz , 2019



Suspension lamp. Structure fixed to the ceiling with stem, available in two heights. Extruded aluminium profile with free rotation system for direct and indirect light, graphite matt electroplated. Dimmable 1-10V driver and pcb led both included.

Type: Suspension lamp

Environment: Indoor

Structure: Aluminium

Voltage: 120 V

Supply: Terminal strip

Dimmable driver included

Light source: PCB LED 50W 3000K 4600Lm  
included

**NITÖ T L**

149030600010 **graphite matt**

 **2.8 kg**  
**5 kg**

 IP-20

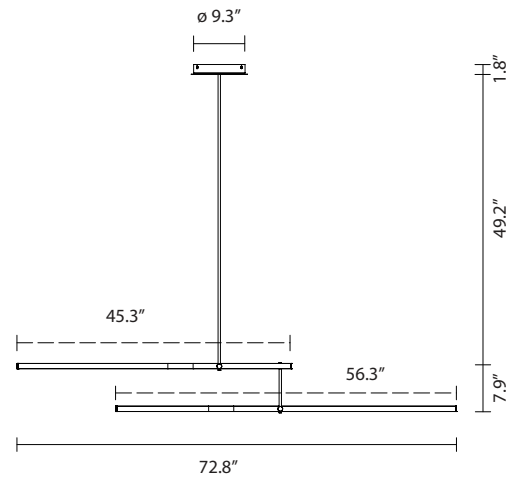

**NITŌ T S**  
by Dominik Lutz , 2019



Suspension lamp. Structure fixed to the ceiling with stem, available in two heights. Extruded aluminium profile with free rotation system for direct and indirect light, graphite matt electroplated. Dimmable 1-10V driver and pcb led both included.

**Type:** Suspension lamp

**Environment:** Indoor

**Structure:** Aluminium

**Voltage:** 120 V

**Supply:** Terminal strip

**Dimmable driver included**

**Light source:** PCB LED 50W 3000K 4600Lm  
included

**NITŌ T S**

148030600010 **graphite matt**

 **2.8 kg**  
**5 kg**

 IP-20

